



HAL
open science

Negative role of surface plasmons in the transmission of metallic gratings with very narrow slits.

Qing Cao, Philippe Lalanne

► **To cite this version:**

Qing Cao, Philippe Lalanne. Negative role of surface plasmons in the transmission of metallic gratings with very narrow slits.. *Physical Review Letters*, 2002, 88 (5), pp.057403. 10.1103/PhysRevLett.88.057403 . hal-00880400

HAL Id: hal-00880400

<https://hal-iogs.archives-ouvertes.fr/hal-00880400>

Submitted on 6 Nov 2013

HAL is a multi-disciplinary open access archive for the deposit and dissemination of scientific research documents, whether they are published or not. The documents may come from teaching and research institutions in France or abroad, or from public or private research centers.

L'archive ouverte pluridisciplinaire **HAL**, est destinée au dépôt et à la diffusion de documents scientifiques de niveau recherche, publiés ou non, émanant des établissements d'enseignement et de recherche français ou étrangers, des laboratoires publics ou privés.

Negative Role of Surface Plasmons in the Transmission of Metallic Gratings with Very Narrow Slits

Qing Cao and Philippe Lalanne

Laboratoire Charles Fabry de l'Institut d'Optique, Centre National de la Recherche Scientifique, BP 147, F-91403 Orsay Cedex, France

(Received 6 July 2001; published 18 January 2002)

It is generally admitted that the extraordinary transmission of metallic grating with very narrow slits is mainly due to the excitation of surface plasmons on the upper and lower interfaces of the grating. We show that the surface plasmon contribution is not the prime effect and that waveguide mode resonance and diffraction are responsible for the extraordinary transmission. Additionally and surprisingly, we reveal that the transmittance of subwavelength metallic gratings is always nearly zero for frequencies corresponding to surface plasmon excitation. This finding implies that surface plasmons play a negative role in the transmission.

DOI: 10.1103/PhysRevLett.88.057403

PACS numbers: 78.66.Bz, 42.79.Dj, 71.36.+c, 73.20.Mf

Recently, several experiments [1] have shown that the transmission of light through metallic films perforated by arrays of subwavelength holes can be up to 2–3 orders of magnitude larger than that predicted by the conventional aperture theory [2]. This surprising discovery has attracted much interest in both the physics [3–9] and the potential numerous applications [10–12] in optics and photonics. With the exception of the work by Treacy [3], it is generally admitted that the extraordinary transmission is mainly due to the excitation of coupled surface plasmons (SP) on the upper and lower interfaces of the metal grating for two-dimensional [1,7–9] and one-dimensional structures [4–7].

In this Letter, a thorough study of the one-dimensional case for frequencies close to the SP band reveals that the SP are not the key mechanism responsible for the extraordinary transmission. This assertion is supported by an analytical model which ignores the genuine nature of the grating ridge but perfectly predicts the peaks and their dispersion. Within the scope of the model, the high transmission is understood as resulting from waveguide-mode resonance and diffraction. Additionally, by studying metallic gratings, for which the energy band of SP is far from the energy associated with Rayleigh anomalies, we show that the transmission is always nearly zero at frequencies corresponding to the SP excitation of the upper grating interface. Consequently, the extraordinary transmission is rather seen as resulting from a vertical waveguide resonance, whereas SP have a negative impact on the transmission. We believe that, for transmission peaks in the SP band, the close energy proximity of Rayleigh anomalies and of SP has rendered confusing the interpretation in previous works.

For the following, it is convenient to consider a bimaterial grating structure surrounded by air; see Fig. 1 for the definition of the grating parameters. As shown, the grating ridges are composed of two different materials. Obviously, classical metallic gratings such as those studied in Refs. [3–7] correspond to the special case of $\epsilon_1 = \epsilon_2$. In Fig. 1, material 1 on either side of the slit

is a metal with a relative permittivity ϵ_1 . If $(b - a)/2$ is much larger than the skin depth of the metal, the channel properties of the slits are identical to those of classical gratings. Material 2 inside the ridge can be a metal or a highly reflective absorber. We denote by ϵ_2 its relative permittivity. For $b \ll \Lambda$, the physical properties on either side of the grating are mainly governed by material 2. The main advantage of the bimaterial structure is that, by varying ϵ_2 , it allows a thorough analysis of the actual role of SP in the remarkable transmission. In the remainder of this paper, we shall refer to the gold grating studied in [5], with $\Lambda = 3.5 \mu\text{m}$ and $a = 0.5 \mu\text{m}$, and with the frequency-dependent gold permittivities ϵ_g given in Ref. [13]. The parameter b is chosen equal to $0.9 \mu\text{m}$. Thus, only hardly 12% of the grating ridge is composed of material 1, and the surface properties of the grating are almost completely determined by material 2.

Let us start by considering the gold grating structure studied in [5], $\epsilon_1 = \epsilon_2 = \epsilon_g$ and $h = 4 \mu\text{m}$ with our notations. The bold curves in Fig. 2 show the zero-order

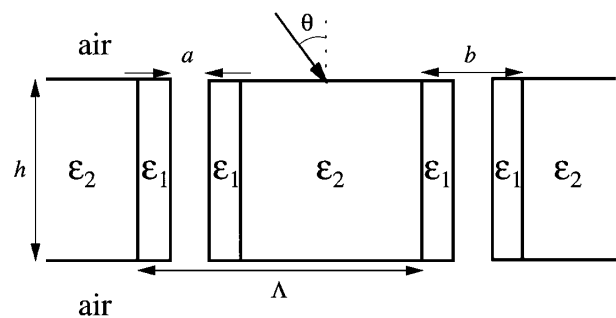

FIG. 1. The investigated bimaterial grating structure. θ is the angle of incidence of the incident plane wave, Λ is the period, a is the slit width, $b - a$ is the total width of material 1, and h is the depth. ϵ_1 and ϵ_2 are the relative permittivities of materials 1 and 2, respectively. Throughout the paper, a TM-polarized illumination is assumed and $\Lambda = 3.5 \mu\text{m}$, $a = 0.5 \mu\text{m}$, and $b = 0.9 \mu\text{m}$. For these values, the channel properties are related to material 1; material 2 governs the surface properties of the grating.

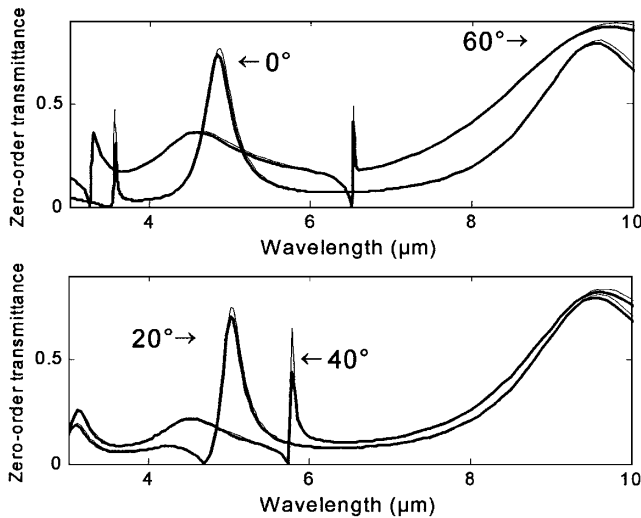

FIG. 2. Zero-order transmittance spectra of gold gratings ($\epsilon_1 = \epsilon_2 = \epsilon_g$) for $h = 4 \mu\text{m}$ and for several values of θ . Bold curves: RCWA data. Thin curves: model predictions according to Eq. (1). The model predictions are highly accurate.

transmittance for TM polarization and for different angles of incidence, $\theta = 0^\circ, 20^\circ, 40^\circ$, and 60° . The computation is performed with the rigorous coupled wave analysis (RCWA), an electromagnetic theory often used for analyzing grating diffraction [14]. The results are in excellent agreement with those of Ref. [5]. At normal incidence, three remarkable transmission peaks are obtained for $\lambda \approx 3.58, 4.9$, and $9.5 \mu\text{m}$ and these peaks offer totally different dispersion relations with θ .

In order to gain physical insight into the diffraction problem, we refer to an *analytical* model [6] published previously by one of the authors for the analysis of metallic gratings with subwavelength slits. In brief, the model relies on two main features. First, it assumes that the electromagnetic field inside the grating is a superposition of two counterpropagating waves, these waves being the fundamental modes propagating forward and backward in an air slit surrounded by two metallic walls. Second, and more importantly for our discussion, when matching the boundary conditions on each side of the grating, it assumes that the ridge material is a perfect reflector. In other words, the model carefully takes into account the properties of the channel but completely ignores the real nature of the ridge material. Therefore, although the contrary was erroneously stated in Ref. [6], it cannot take into account phenomena linked to the genuine nature of the ridge, such as collective oscillations of SP. Within the scope of the model, the zero-order transmission is expressed as [6]

$$T_0 = \left| \frac{t_{12}t_{21}u}{(1 - r_{12}^2u^2)p_1 \cos\theta} \right|^2, \quad (1)$$

where $t_{12} = 2p_2/(p_1 + p_2)$, $t_{21} = 2p_1/(p_1 + p_2)$, $r_{12} = (p_2 - p_1)/(p_1 + p_2)$, $p_1 = \sum_{m=-\infty}^{\infty} g_m^2 k_0 / \sqrt{k_0^2 - k_{x,m}^2}$, $p_2 = \Lambda/(n_{\text{eff}}a)$, $u = \exp(-in_{\text{eff}}k_0h)$, $k_{x,m} = k_0 \sin\theta +$

mK , $K = 2\pi/\Lambda$, $g_m = \text{sinc}(mKa/2)$, with $\text{sinc}(\dots)$ being the sinc function, n_{eff} the effective index of the fundamental waveguide mode, and m a relative integer. Thus, the genuine metallic nature of the grating reflects only in the value of n_{eff} , i.e., in the propagation constant of the fundamental waveguide mode. The zero-order transmittance predicted by the model is shown by the thin curves in Fig. 2. As shown from the comparison of the model predictions and the RCWA results, the model is able to predict the remarkable transmission peaks, their *locations*, their linewidths, and their θ dependence. The model predictions are *highly accurate*. The only discrepancies occur at resonance, the peak transmittance predicted by the model being slightly higher than those obtained by exact electromagnetic computations. Although not shown here for the sake of conciseness, the model also predicts the reflection and the absorption.

Within the scope of the model, the transmittance-resonance wavelengths (the poles of the scattered waves) are seen as the zeros of the imaginary part of the factor $r_{12}u$. These zeros occur for ‘‘Fabry-Pérot resonance’’ conditions

$$k_0 \text{Re}(n_{\text{eff}})h - \arg(r_{12}) = m\pi. \quad (2)$$

The first term in Eq. (2) is independent of θ and stipulates that resonance occurs for cavity lengths equal to a multiple of half of the waveguide-mode wavelength. The second term is an additional phase shift experienced by the fundamental mode when reflecting at the grating interfaces. Analytically, we find that this phase shift is almost independent of θ for $\lambda \gg \Lambda$, but that it quickly varies with θ for $\lambda \approx \Lambda$, in agreement with Fig. 2. More specifically, the sharp variations occur whenever one of the denominators in p_1 is null, i.e., for energetic positions corresponding to Rayleigh anomalies, $\sin(\theta) + m\lambda/\Lambda = \pm 1$. These sharp phase shifts are responsible for the strong dependence on θ of the extraordinary transmission for $\lambda \approx \Lambda$. Thus, within the scope of the model, the strong dependence on θ of the resonance peak close to $\lambda \approx \Lambda$ for $\theta = 0$, which is attributed to SP in Refs. [1,4,5,7], is understood as a pure diffraction effect associated with a redistribution of energy and phase among several diffraction orders. As a consequence, it is appropriate to invoke surface currents, rather than SP, as the general mechanism responsible for the extraordinary transmission. Surface currents exist both on real and perfectly conducting metal surfaces and are well known to enhance the transmission through perfectly metallic subwavelength apertures [15]. Perhaps, the close energy proximity of Rayleigh anomalies and of SP resonance may have rendered confusing the interpretation in previous works.

Apart from the transmittance peaks, Fig. 2 also exhibits another remarkable feature, namely, the presence of zeros at energetic positions slightly smaller than those corresponding to Rayleigh anomalies. These zeros are nearly real, and the corresponding transmittance is extremely

weak, $\approx 10^{-8}$ – 10^{-5} . Surprisingly, we found that this *nearly null transmittance occurs when the momentum of the incident wave matches the SP momentum of a flat interface* [16] through the grating momentum wave vector, i.e., for wavelengths λ_{SP} given by

$$\lambda_{\text{SP}} = \frac{\Lambda}{m} [\text{Re}\{\{\varepsilon_2/(1 + \varepsilon_2)\}^{1/2}\} \pm \sin(\theta)], \quad (3)$$

with m a nonzero relative integer. We have checked this property with many numerical computations performed with the RCWA. The main results are summarized in Fig. 3. Figure 3(a) is relative to metallic gratings defined by $\varepsilon_2 = \varepsilon_1 = (0.1341 - in'')^2$, for $3 < n'' < 12$ and $\theta = 0$. The stars correspond to the wavelength λ_{min} for which a minimum transmission occurs. The solid curve corresponds to the function $\lambda = \lambda_{\text{SP}}(n'')$ for $m = 1$. Over the broad interval of n'' values, λ_{min} almost coincides with λ_{SP} . They are actually indistinguishable for $n'' \geq 5$. In Fig. 3(b), the special case $n'' = 5$ is considered. The thin solid curve is obtained for $h = 4 \mu\text{m}$ and for an angle of incidence, $\theta = 45^\circ$. The bold curves hold for $\theta = 0^\circ$ and for two different depths, $h = 4$ and $1.2 \mu\text{m}$. The vertical arrows on the horizontal axis correspond to the λ_{SP} values of Eq. (3). Again, λ_{min} and λ_{SP} are nearly identical, the largest deviation does not exceed 15 nm. Additionally, we have checked that the zeros are also observed when the relative permittivity ε of the substrate or the incident medium differs from unity. In those cases, the zeros still occur for λ_{SP} provided that, in Eq. (3), we replace the square-root function by the classical SP normalized wave vector $[\varepsilon\varepsilon_2/(\varepsilon + \varepsilon_2)]^{1/2}$ at a metal-dielectric inter-

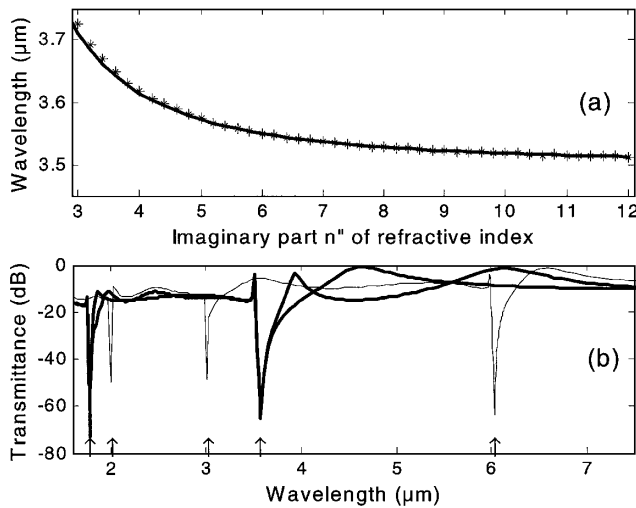

FIG. 3. Nearly null transmission for $\lambda = \lambda_{\text{SP}}$. (a) $\theta = 0$. The stars show the locations λ_{min} of the transmittance minima of metallic gratings for $\varepsilon_1 = \varepsilon_2 = (0.1341 - in'')^2$ and $h = 4 \mu\text{m}$ as a function of n'' . The bold curve is the function $\lambda = \lambda_{\text{SP}}(n'')$ for $m = 1$. (b) Zero-order transmittance spectra of gratings defined by $\varepsilon_1 = \varepsilon_2 = (0.1341 - 5i)^2$ for different values of h and θ . The vertical arrows on the horizontal axes correspond to the λ_{SP} values of Eq. (3). Bold curves: $\theta = 0$, and $h = 1.2$ and $4 \mu\text{m}$. Thin curve: $\theta = 45^\circ$, and $h = 4 \mu\text{m}$.

face [16]. It is concluded that the observation of zeros for SP frequencies is a very general property of metallic gratings with subwavelength slits. It is valid for oblique incidence, for any grating depth, and for arbitrary dielectric-metal interfaces. For larger slits, however, this property is no longer true.

To understand the physical origin of the minimum transmission, we plotted the total electromagnetic fields at the upper grating interface for $\lambda = \lambda_{\text{SP}}$ and for several values of θ , using the RCWA. We observed that the field on the metallic ridges is mainly formed by the interference of the excited order (two orders are equally excited under normal incidence), the incident plane wave, and the nearly unit-amplitude-reflected zero order. This interference results in a nearly null field distribution inside the slit and explains the transmittance dip observed for $\lambda = \lambda_{\text{SP}}$. We also observed through numerical computations that the spectral width of the dip increases with the metal absorption, indicating that this spectral width is related to an internal damping. We interpret these observations by presuming that the *zero transmittance is related to the excitation of a wave with a SP character* on the upper interface, or on the lower interface if the refractive indices of the incident medium and the substrate are different. The propagation of the SP on the interface is only weakly affected by the presence of the narrow apertures. In other words, SP launched on the interface fly over the air aperture. Thus the surface almost behaves like a flat surface, and the propagation constant of the SP is nearly that of a flat interface, in agreement with Eq. (3).

Equations (2) and (3) mainly govern the transmission properties of metallic gratings with subwavelength slits. Apparently, two different mechanisms compete in the transmission. On one side, the excitation of SP on the upper interface results in a null transmission, and, on the other side, the Fabry-Pérot resonance provides high transmission. Out of curiosity, let us study situations for which both the SP excitation and the Fabry-Pérot resonance occur for the same frequency. For that purpose, we consider again gold gratings ($\varepsilon_1 = \varepsilon_2 = \varepsilon_g$). For $h = 4 \mu\text{m}$, the transmission spectrum shown by the bold curve in Fig. 4(a) exhibits a remarkable peak for $\lambda \approx 3.59 \mu\text{m}$. Then, we further consider a specific grating for which the two resonance conditions of Eqs. (2) and (3) are simultaneously satisfied for $\lambda \approx 3.59 \mu\text{m}$. Such a situation holds for bimaterial structures defined by $\varepsilon_1 = \varepsilon_g$ (a gold channel is considered again) and by $\varepsilon_2 = (0.01 - 4.5i)^2$, a specific value for which Eq. (3) is satisfied for $\lambda_{\text{SP}} = 3.59 \mu\text{m}$ and $\theta = 0$. The thin curve in Fig. 4(a) shows the transmission spectra of the bimaterial structure. It is remarkable that the transmission peak for $\lambda \approx 3.59 \mu\text{m}$ completely disappears, while the two others at larger wavelengths are nearly unaffected. Figure 4(b) holds for a reverse situation. For $h = 3.1 \mu\text{m}$, the bimaterial grating exhibits a sharp and intense peak for $\lambda \approx 3.51 \mu\text{m}$, whereas the gold grating does not

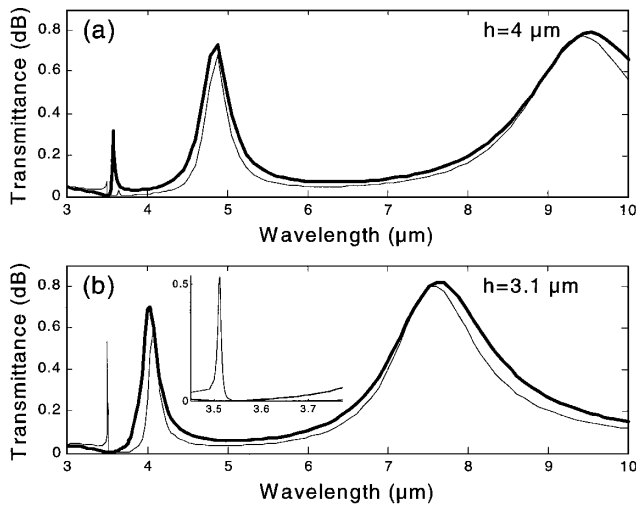

FIG. 4. Negative role of SP: absence or presence of the extraordinary transmission for $\lambda \approx \Lambda$ according to the respective locations of Fabry-Pérot resonance and of the zero transmission. The bold curves hold for gold gratings and the thin curves for bimaterial gratings defined by $\epsilon_1 = \epsilon_g$ and $\epsilon_2 = (0.01 - 4.5i)^2$. (a) For $h = 4 \mu\text{m}$, the high transmission observed for the gold grating at $\lambda \approx \Lambda$ is hidden by the SP of the bimaterial grating. (b) For $h = 3.1 \mu\text{m}$, a reverse situation is observed. The inset represents an enlarged view in the SP band.

because of the zero at $\lambda \approx \lambda_{\text{SP}} = 3.504 \mu\text{m}$. These two examples show the primacy of the zero and the negative role of SP in the transmission mechanism.

In conclusion, we have revealed that SP is not the prime mechanism responsible for the extraordinary transmission of subwavelength metallic gratings with very narrow slits. Within the scope of an analytical model, we have shown that waveguide-mode resonance and diffraction, as well, are important. In fact, when the upper interface of the grating is excited by SP, this excitation results in nearly zero transmission, which implies that SP play a negative role in the transmission. Moreover, we believe that the bimaterial structure proposed in this work is an elegant tool

for differentiating the respective properties of the channel and of the upper and lower interfaces with respect to the SP. If it can be fabricated, this structure may also be optimized to achieve a high transmission in a chosen spectral range, a crucial point for applications. We hope that these results are also helpful for understanding the extraordinary transmission observed experimentally for two-dimensional grating structures.

We are indebted to K.D. Möller, J.P. Hugonin, and P. Chavel for many fruitful discussions.

-
- [1] T.W. Ebbesen *et al.*, *Nature (London)* **391**, 667 (1998); H.F. Ghaemi *et al.*, *Phys. Rev. B* **58**, 6779 (1998); D.E. Grupp *et al.*, *Appl. Phys. Lett.* **77**, 1569 (2000).
 - [2] H.A. Bethe, *Phys. Rev.* **66**, 163 (1944).
 - [3] M.M.J. Treacy, *Appl. Phys. Lett.* **75**, 606 (1999).
 - [4] U. Schröter and D. Heitmann, *Phys. Rev. B* **58**, 15 419 (1998).
 - [5] J.A. Porto, F.J. Garcia-Vidal, and J.B. Pendry, *Phys. Rev. Lett.* **83**, 2845 (1999).
 - [6] Ph. Lalanne *et al.*, *J. Opt. A* **2**, 48 (2000).
 - [7] E. Popov *et al.*, *Phys. Rev. B* **62**, 16 100 (2000).
 - [8] L. Martin-Moreno *et al.*, *Phys. Rev. Lett.* **86**, 1114 (2001).
 - [9] L. Salomon *et al.*, *Phys. Rev. Lett.* **86**, 1110 (2001).
 - [10] T.J. Kim *et al.*, *Opt. Lett.* **24**, 256 (1999).
 - [11] R. Sambles, *Nature (London)* **391**, 641 (1998).
 - [12] T. Thio *et al.*, *Physica (Amsterdam)* **279B**, 90 (2000).
 - [13] For the numerical computations, we use the frequency-dependent gold permittivities ϵ_g of *Handbook of Optical Constants of Solids*, edited by E.D. Palik (Academic, Orlando, 1985).
 - [14] Ph. Lalanne and G.M. Morris, *J. Opt. Soc. Am. A* **13**, 779 (1996); M.G. Moharam *et al.*, *J. Opt. Soc. Am. A* **12**, 1068 (1995).
 - [15] J.R. Andrewartha *et al.*, *Opt. Acta* **26**, 69 (1979).
 - [16] H. Raether, *SP on Smooth and Rough Surfaces and on Gratings* (Springer-Verlag, Berlin, 1988).