



HAL
open science

Megawatt peak power, 1 kHz, 266 nm sub nanosecond laser source based on single-crystal fiber amplifier

Loïc Deyra, Igor Martial, Julien Didierjean, François Balembois, Patrick Georges

► **To cite this version:**

Loïc Deyra, Igor Martial, Julien Didierjean, François Balembois, Patrick Georges. Megawatt peak power, 1 kHz, 266 nm sub nanosecond laser source based on single-crystal fiber amplifier. Applied Physics B - Laser and Optics, 2013, 10.1007/s00340-013-5376-7 . hal-00819328

HAL Id: hal-00819328

<https://hal-iogs.archives-ouvertes.fr/hal-00819328>

Submitted on 30 Apr 2013

HAL is a multi-disciplinary open access archive for the deposit and dissemination of scientific research documents, whether they are published or not. The documents may come from teaching and research institutions in France or abroad, or from public or private research centers.

L'archive ouverte pluridisciplinaire **HAL**, est destinée au dépôt et à la diffusion de documents scientifiques de niveau recherche, publiés ou non, émanant des établissements d'enseignement et de recherche français ou étrangers, des laboratoires publics ou privés.

Megawatt peak power, 1 kHz, 266 nm subnanosecond laser source based on single-crystal fiber amplifier

Loïc Deyra^{1*}, Igor Martial², François Balembois¹, Julien Diderjean², Patrick Georges¹

1. Laboratoire Charles Fabry, Institut d'Optique, CNRS, Univ Paris-Sud, 91127 Palaiseau, France

2. Fibercryst SAS, La Doua Bâtiment l'Atrium, Boulevard Latarjet, F 69616 Villeurbanne Cedex, France

*Corresponding author: loic.deyra@institutoptique.fr

Received Month X, XXXX; revised Month X, XXXX; accepted Month X, XXXX; posted Month X, XXXX (Doc. ID XXXXX); published Month X, XXXX

We report the realization of a UV source based on the fourth harmonic generation with LBO/BBO of a Nd:YAG passively Q-switched oscillator amplified in a single-crystal fiber. With careful optimization of the nonlinear components and parameters, we obtain 530 mW average power at 266 nm with pulses of 540 ps at the repetition rate of 1 kHz, which represents a 22.7% total conversion efficiency from IR to UV and nearly 1 MW peak power. The beam quality M^2 is measured to be below 2.

OCIS Codes: 000.0000, 999.9999

The development of solid state UV lasers has been a major industrial challenge for various applications, among them spectroscopy, lithography, material processing, or ophthalmology.

Various optical designs have been used to obtain high conversions efficiencies, the two most efficient being cavity enhanced setups for CW fourth harmonic generation [1] or high peak power external frequency conversion schemes. Among the latest, record efficiencies have been obtained by microchip lasers [2], but the average power and beam quality were limited. In most of those systems, a master oscillator power amplifier (MOPA) is used to increase the fundamental beam energy [3-4]

In the past few years, single-crystal fiber (SCF) technology has proved to be an interesting solution to boost the performance of passively Q-switched microchip lasers [5]: it provides unique combination of high gain, high peak power and significant average power, with the most simple amplification scheme possible (one or two passes).

In this Letter, we present a 266 nm UV source based on the fourth harmonic generation of a Nd:YAG single-crystal fiber Master Oscillator Power Amplifier (MOPA) previously developed [5].

The 1064 nm amplified laser system is described in detail in [5]. It is composed by a microchip laser amplified with a Nd:YAG single-crystal fiber in double pass configuration. It delivers a maximum of 2.3 W at 1 kHz with pulses of 550 ps and an excellent beam quality ($M^2_x=1.06$, $M^2_y=1.06$), reaching a peak power of more than 4 MW.

The frequency conversion scheme is presented in Fig.1. A combination of a half waveplate and a polarizer is used to control the incident IR power. The second harmonic generation to 532 nm is realized in a 3x3x15 mm LiB_3O_5 (LBO) cut at $\theta=90$, $\phi=11.3^\circ$ for type I critically phase matched SHG. We chose a LBO crystal because of its excellent crystal quality even in long crystals, large angular acceptance and good d_{eff} value.

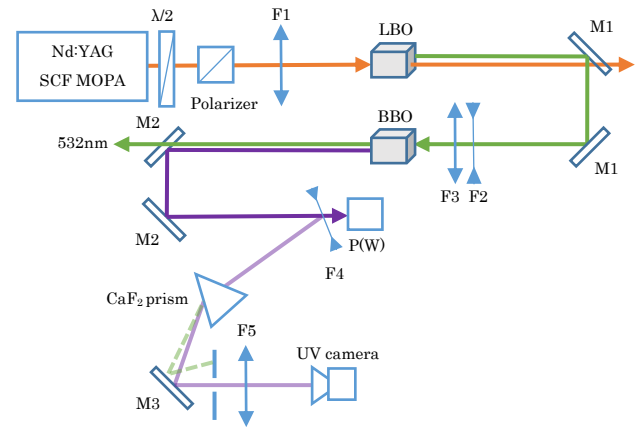

Figure 1: Experimental setup (SCF: single crystal fiber)

Two dichroic mirrors M1 coated for HR at 532 nm and HT at 1064 nm are used to filter the residual 1064 nm beam. High power coatings need to be used due to the very high intensities impacting the mirrors ($>2\text{J}/\text{cm}^2$).

Different lenses (F1) are used to optimize the IR beam size inside the LBO in order to maximize the conversion efficiency. Three lenses of focal 400 mm, 300 mm and 250-mm were tested, corresponding respectively to waist diameters of 1250 μm , 850 μm and 500 μm . The LBO is then placed at the laser waist. In all of those cases the Rayleigh range largely exceeds the crystal length.

Figure 2 shows the conversion efficiency in the green versus the fundamental power. Saturation effect is clearly visible for a diameter of 500 μm .

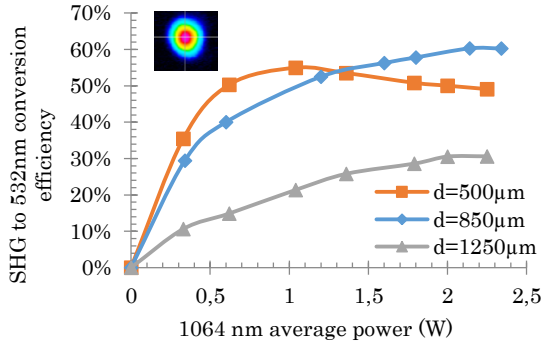

Figure 3 : SHG from 1064 to 532 nm conversion efficiency for different focal lengths and spatial profile of the green

An intermediate beam diameter of 850 μm leads to the maximum conversion efficiency of 61%, with 1.41 W of 532 nm obtained at 2.3 W of 1064 nm input power. The green beam operates in TEM₀₀ with a measured M² of M²_x=1.02 and M²_y=1.05, with pulse duration of 640 ps (see Fig.6). The slight broadening of the pulse duration is directly linked to slight saturation of the SHG process that occurs at high conversion efficiencies. The output power is stable without any temperature control thanks to the large thermal acceptance and low absorption of the LBO crystal.

The setup is then completed with a second conversion stage from 532 nm to 266 nm. At this wavelength, only two crystals have shown record efficiencies, β -BaB₂O₄ (BBO) and CsLiB₆O₁₀ (CLBO) [2,6]. Although CLBO has very interesting optical properties (large angular acceptance, low absorption in UV), it is very hygroscopic, making its utilization very difficult. Therefore, the chosen UV crystal is a β -BaB₂O₄ crystal cut for type I SHG at 266nm and with dimensions of 4x9.5x9.5 mm. The crystal is not AR coated. It is mounted on a copper mount cooled at 10°C firstly to improve the thermal contact, but also to increase the UV output stability by reducing the UV absorption coefficient[7]. An afocal imaging system composed of a divergent lens F2 and a convergent lens F3 is used to adjust the green beam in the BBO at the appropriate diameter. Different focal lengths are used to create beam diameters of 1 mm, 1.3 mm and 2 mm inside the UV crystal.

Two dichroic mirrors M2, coated for HR at 266 nm and HT at 532 nm both at a 45° incidence angle, are used to isolate the generated 266 nm harmonic.

Reflection on a wedged window M3 is used to image the UV beam on a windowless Spiricon CCD camera. This camera is sensitive down to 180 nm but with a much lower sensitivity than at 532 nm. For this reason, a CaF₂ prism in combination with a diaphragm is used to eliminate the residual green photons that interfere with the UV measurement. The imaging system provides beam profiling, M² measurement when a UV fused silica lens F5=80 mm is added, and also is extremely helpful in the phase matching of the BBO crystal. Indeed, the absorption of the BBO in the UV spectrum brings a temperature elevation during the phase matching tuning

that, combined with low thermal acceptance of BBO, renders the optimization difficult. Optimizing the UV output power by monitoring the UV beam profile allows a much faster response in comparison with a thermal powermeter.

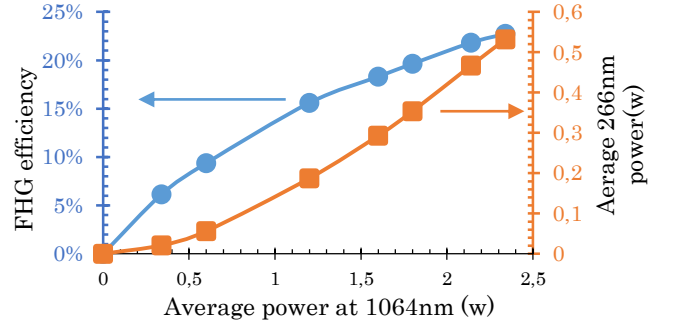

Figure 2: Average power at 266 nm obtained (right axis) and IR to UV conversion efficiency (left)

The maximum power in the UV was obtained for a beam diameter of 1.3 mm in the BBO: we observe that larger beams limit conversion efficiency, and that smaller beams saturate the efficiency at low powers. Figure 3 shows the output 266 nm average power and the corresponding IR to UV conversion efficiency. A stable output of 530 mW at 266 nm is obtained for 2.3 W of 1064 nm input power, which represents a total conversion efficiency from IR to UV of 22.7%. The conversion efficiency from green to UV can be here calculated at 38%. It could be improved with appropriate AR coatings on the BBO.

Absorption losses have been measured by placing an identical BBO crystal at normal incidence before the power meter, leading to an UV drop of the measured 266 nm power by 23%. By deducing the Fresnel losses at the BBO interfaces, its absorption coefficient at 266 nm can then be deduced as $\alpha=0.127 \text{ cm}^{-1}$. Although quite high, this value is in the order of typical flux-grown BBO [2]. This absorption value, added with the fact that we are able to saturate the conversion efficiency at low input power, indicates that we could use smaller crystal of a few millimeters that will reduce the total absorption while maintaining the same conversion efficiency.

From the absorption value, we can estimate the maximum temperature elevation in the BBO due to the UV absorption and compare it with the thermal acceptance of BBO cut for type I SHG at 266nm (6 K.cm, value given by SNLO). By assuming the heat flow in the BBO as radial, we can use the equations defined in [8]. The maximum axial temperature elevation in the center of the crystal between its entrance and its end can be expressed as follow[9] :

$$\Delta T = -\frac{\alpha P_{UV}}{4\pi K_c} \left(\ln \left(\frac{r_0^2}{w_0^2} \right) + 1 \right) \quad (1)$$

With α being the absorption coefficient of BBO at 266 nm, K_c the thermal conductivity of BBO (1.4 W/m/K), r_0 the crystal radius, w_0 the UV laser radius and P_{UV} the 266 nm average power at the crystal output. If we assume a crystal diameter of 7 mm (average of the transverse

dimension of our BBO), a laser diameter of 1.3 mm, and a UV power of 530 mW, we estimate a maximum temperature gradient of 2 K in the crystal. Since this value is in the order of the thermal acceptance, axial phase mismatch should have an effect on the conversion process as mentioned in several works [10-12]. We think that the secondary intensity peak of the UV beam profile (Fig.4) is related to this effect: axial phase mismatching reveals the side bands of the sinc^2 SHG efficiency curve. Further experiments will be performed to confirm this

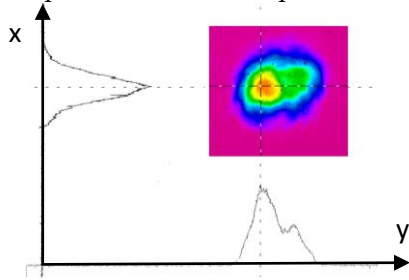

Figure 4: Beam profile and xy-axis intensity distribution of the 266nm beam

hypothesis.

Despite this secondary intensity peak, the measured M^2 remains good with values of $M^2_x=1.2$ and $M^2_y=1.4$ (Fig.5). It is important to note that the very sensible tuning of the BBO crystal and the low sensitivity of the CCD camera at 266 nm leads to a high uncertainty on the M^2 measurement. Therefore, we estimated the UV M^2 to be between 1.2 and 1.9.

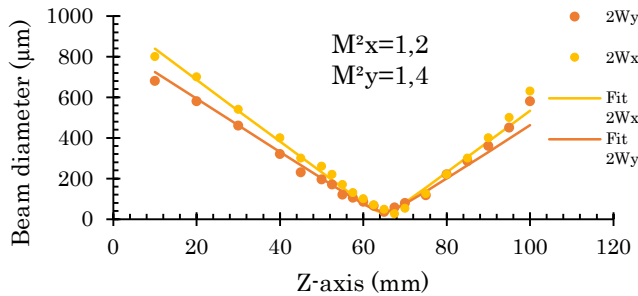

Figure 5: M^2 measurement of the 266 nm beam

The temporal profiles of the IR, green and UV pulses are displayed in Fig 6. The measured pulse duration of the UV beam is 540 ps.

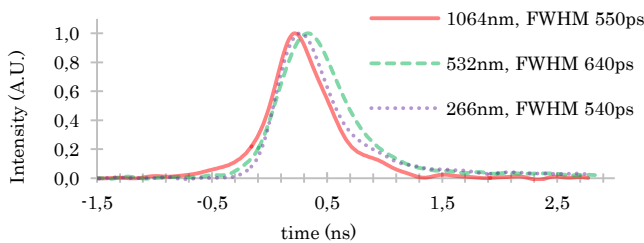

Figure 6: Pulse widths of IR, green and UV beams

In conclusion, we demonstrate here a 266 nm laser source based on the fourth harmonic generation of a single-crystal fiber MOPA with LBO/BBO crystals. We reach 22.7% of total conversion efficiency from infrared to UV. We obtain a 266 nm output of 530 mW, at 1 kHz with pulses width of 540 ps. This represents a peak power of 980 kW. We measure the UV beam profile and determine its M^2 to be <2 . To the best of our knowledge, this is the first realization of a 266 nm sub nanosecond source based on passively Q-switched oscillator with MW peak power combined with half-watt average power. This work demonstrates the potential of single-crystal fiber amplifiers for high performance UV MOPA systems.

Loïc Deyra acknowledges the DGA for the funding of his PhD. We thank Alain Maillard (LMOPS Laboratory of University de Lorraine and Supélec, France) and Philippe Villeval (Cristal Laser, France) for the elaboration, orientation, cutting and polishing of the BBO crystals.

References

1. T. Südmeyer, Y. Imai, H. Masuda, N. Eguchi, M. Saito, and S. Kubota *Optic Express*, vol. 16, no. 3, pp. 1546–1551 (2008)
2. R. Bhandari, T. Taira, A. Miyamoto, Y. Furukawa, and T. Tago, *Optical Materials express*, vol. 2, no. 7, pp. 907–913 (2012)
3. Y. Zaouter, M. Hanna, F. Morin, M. Tonin, R. Maleck, C. Hoenninger, E. Mottay, and P. Georges, *Lasers, Sources, and Related Photonic Devices*, OSA Technical Digest (CD) (Optical Society of America, 2012), paper FTh5A.2.
4. S. Pierrot, F. Liegeois, J. Saby, B. Cocquelin, Y. Hernandez, F. Salin, and D. Giannone, *Fiber Laser Applications*, OSA Technical Digest (CD) (Optical Society of America, 2011), paper JWA5.
5. I. Martial, F. Balembois, J. Didierjean, and P. Georges, *Optic Express*, vol. 19, no. 12, pp. 11667–79 (2011)
6. G. Wang, A. Geng, Y. Bo, H. Li, Z. Sun, Y. Bi, D. Cui, Z. Xu, X. Yuan, X. Wang, G. Shen, and D. Shen, *Optics Communications*, vol. 259, no. 2, pp. 820–822 (2006).
7. A. J. Merriam, J. J. Jacob, D. S. Bethune, and J. A. Hoffnagle, OSA Technical Digest Series (CD) (Optical Society of America, 2007), paper MB11.
8. S. Chénais, F. Druon, and S. Forget, *Progress in Quantum Electronics, Volume 30, Issue 4, p. 89-153* (2006)
9. J. Didierjean, E. Herault, F. Balembois, and P. Georges, *Optics express*, vol. 16, no. 12, pp. 8995–9010 (2008)
10. M. Takahashi, A. Osada, A. Dergachev, P. F. Moulton, M. Cadatal-Raduban, T. Shimizu, and N. Sarukura, *Japanese Journal of Applied Physics*, vol. 49, no. 8, p. 080211, Aug. (2010)
11. Z. M. Liao, S. A. Payne, J. W. Dawson, A. D. Drobshoff, C. A. Ebberts, D. M. Pennington, I. Jovanovic, and L. R. Taylor, *Nonlinear Optics: Materials, Fundamentals and Applications*, Technical Digest (CD) (Optical Society of America, 2004), paper WD17.
12. M. Takahashi, A. Osada, A. Dergachev, P. F. Moulton, M. Cadatal-raduban, T. Shimizu, and N. Sarukura, *Journal of Crystal Growth*, vol. 318, pp. 606–609 (2011)

Information Page

References

1. T. Südmeyer, Y. Imai, H. Masuda, N. Eguchi, M. Saito, and S. Kubota, "Efficient 2nd and 4th harmonic generation of a amplifier," *Optic Express*, vol. 16, no. 3, pp. 1546–1551, 2008.
2. R. Bhandari, T. Taira, A. Miyamoto, Y. Furukawa, and T. Tago, "3 MW peak power at 266 nm using Nd:YAG/Cr⁴⁺:YAG microchip laser and fluxless-BBO," *Optical Materials express*, vol. 2, no. 7, pp. 907–913, 2012.
3. Y. Zaouter, M. Hanna, F. Morin, M. Tonin, R. Maleck, C. Hoenninger, E. Mottay, and P. Georges, "Frequency Conversion from IR to UV of High Peak Power Ultrafast Fiber Amplifier," in *Lasers, Sources, and Related Photonic Devices*, OSA Technical Digest (CD) (Optical Society of America, 2012), paper FTTh5A.2.
4. S. Pierrot, F. Liegeois, J. Saby, B. Cocquelin, Y. Hernandez, F. Salin, and D. Giannone, "All Fibre High repetition rate, High Power Picosecond Laser and UV generation," in *Fiber Laser Applications*, OSA Technical Digest (CD) (Optical Society of America, 2011), paper JWA5.
5. I. Martial, F. Balembois, J. Didierjean, and P. Georges, "Nd:YAG single-crystal fiber as high peak power amplifier of pulses below one nanosecond," *Optic Express*, vol. 19, no. 12, pp. 11667–79, Jun. 2011.
6. G. Wang, A. Geng, Y. Bo, H. Li, Z. Sun, Y. Bi, D. Cui, Z. Xu, X. Yuan, X. Wang, G. Shen, and D. Shen, "28.4W 266nm ultraviolet-beam generation by fourth-harmonic generation of an all-solid-state laser," *Optics Communications*, vol. 259, no. 2, pp. 820–822, Mar. 2006.
7. A. J. Merriam, J. J. Jacob, D. S. Bethune, and J. A. Hoffnagle, "Efficient Nonlinear Frequency Conversion to 193-nm Using Cooled BBO," in *Advanced Solid-State Photonics*, OSA Technical Digest Series (CD) (Optical Society of America, 2007), paper MB11.
8. S. Chénais, F. Druon, and S. Forget, "On thermal effects in solid-state lasers: The case of ytterbium-doped materials," *Progress in Quantum Electronics, Volume 30, Issue 4*, p. 89-153 (2006).
9. J. Didierjean, E. Herault, F. Balembois, and P. Georges, "Thermal conductivity measurements of laser crystals by infrared thermography. Application to Nd-doped crystals," *Optics express*, vol. 16, no. 12, pp. 8995–9010, Jun. 2008.
10. M. Takahashi, A. Osada, A. Dergachev, P. F. Moulton, M. Cadatal-Raduban, T. Shimizu, and N. Sarukura, "Effects of Pulse Rate and Temperature on Nonlinear Absorption of Pulsed 262-nm Laser Light in β -BaB₂O₄," *Japanese Journal of Applied Physics*, vol. 49, no. 8, p. 080211, Aug. 2010.
11. Z. M. Liao, S. A. Payne, J. W. Dawson, A. D. Drobshoff, C. A. Ebberts, D. M. Pennington, I. Jovanovic, and L. R. Taylor, "Thermally induced dephasing in periodically poled KTiOPO₄ nonlinear crystals," in *Nonlinear Optics: Materials, Fundamentals and Applications*, Technical Digest (CD) (Optical Society of America, 2004), paper WD17.
12. M. Takahashi, A. Osada, A. Dergachev, P. F. Moulton, M. Cadatal-raduban, T. Shimizu, and N. Sarukura, "Improved fourth harmonic generation in BBO by tight elliptical focusing perpendicular to walk-off plane.pdf," *Journal of Crystal Growth*, vol. 318, pp. 606–609, 2011.