

Sub-Shot-Noise Manipulation of Light Using Semiconductor Emitters and Receivers

J.-F. Roch, J.-Ph. Poizat, and P. Grangier

Institut d'Optique Théorique et Appliquée, B.P. 147, 91403 Orsay Cedex, France

(Received 5 March 1993)

We describe an amplifying system using a photodiode and a light emitting diode, which is able to measure and to "recreate" the quantum statistics of the intensity of a light beam. This system acts therefore as a nonclassical "quantum optical repeater." The overall information transfer is improved by a factor of 1.8 compared to a classical device, while the ideal quantum value would be 2, and the correlation between the signal and meter outputs is 1.2 dB below the shot-noise limit. We also demonstrate the use of this device for both detecting and recreating an input squeezed state.

PACS numbers: 42.50.Dv, 42.50.Lc, 85.60.Dw, 85.60.Jb

It has been known for several years that the conversion from light to electrical current and from electrical current to light can be realized below the optical standard quantum limit, using high efficiency semiconductor electro-optical devices. Indeed, the ability of photodiodes to detect sub-shot-noise light by turning it into sub-shot-noise current is a fundamental property of quantum optics [1], and has been experimentally demonstrated by the observation of squeezing [2]. The quantum properties of the inverse transformation are due to the work of Yamamoto and co-workers on semiconductor lasers [3] (see also Refs. [4,5]). More recently, the appearance of high efficiency light emitting diodes (LED) made possible the use of these simple devices for generating nonclassical light [6-8].

An interesting feature of an electrical current is that its noise at RF frequencies is usually dominated by thermal (Johnson-Nyquist) noise [9], whose power can be made much smaller than the shot-noise level corresponding to the same average current intensity [5,6,10]. In this regime, the electrical current behaves classically, and can therefore be measured, duplicated, or amplified without the quantum constraints attached to a light field. If one is concerned by the nondestructive measurement of the intensity of a light beam, one may imagine converting the light via a photodiode into an electrical current, to measure this current, eventually to amplify it, and to convert it back to a light field using a semiconductor light emitter [11]. Though not being a quantum nondemolition (QND) measurement according to the original definition of this concept [12], this device when considered as a "black box" would have basically the same functionality, provided that both photon-to-electron and electron-to-photon conversion rates are unity. This point will be shown in more detail below using the "QND criteria" which have been introduced to characterize QND measurements in the optical domain [13-17]. But, while the quantum efficiency of infrared photodiodes is not too far from unity (around 0.9), good quantum conversion rates are not as easy to achieve for semiconductor light emitters. The observation of 8.3 dB noise reduction below shot noise by Richardson, Machida, and Yamamoto demonstrated that some laser diodes operating well

above their threshold have high quantum conversion rates [18]. This is to be compared with the best conversion rate of commercial LED, which is around 0.3 when cooled at $T=80$ K (-1.5 dB squeezing). However, the low cost and the simplicity of use of LED make them particularly well suited for experimental tests [6-8], such as the one carried out in this paper.

In this Letter, our aim is to demonstrate that sub-shot-noise manipulation of light beams can be implemented using commercial semiconductor emitters and receivers, by simple electronic operation on an intermediate electrical current which replicates the statistical fluctuations of the photon flux of a light beam. In particular, we will show that this system meets the criteria introduced in the literature to characterize QND measurements [13-17]. Experiments satisfying these criteria have already been performed using the cross Kerr effect in an atomic beam [16,17], and a type-II pulsed parametric amplifier in a KTP crystal [19].

According to the above-mentioned criteria, the effectiveness of a QND measurement can be characterized by three properties: (1) The signal should not be excessively degraded by the measurement (nondemolition property). (2) The meter channel should pick up some information about the signal beam so that a measurement is actually performed (efficiency of the measurement). (3) The meter output should be quantum correlated with the signal output so that its readout does give some information about the outgoing signal (output quantum correlation).

The first two criteria are in-out properties that can be experimentally measured by looking at the faithfulness of the transfer of an input signal-to-quantum-noise ratio (SNR or simply R in the equations) toward the signal and meter output channels [15,17,20]. The input SNR is defined as the ratio of the power of a classical modulation at a given frequency by the quantum noise power at the same frequency for a given observable X ,

$$R = \langle X \rangle^2 / \langle \Delta X^2 \rangle, \quad (1)$$

where all quantities are defined in the frequency domain [15]. The signal nondegradation property is therefore evaluated by (the subscript s refers to the signal and m to the meter)

$$T_s = R_s^{\text{out}}/R_s^{\text{in}} = V_s^{\text{in}}/(V_s^{\text{in}} + N_s^{\text{eq}}), \quad (2)$$

where V_s^{in} is the variance of the input light beam normalized to the shot noise ($V_s^{\text{in}}=1$ for a coherent state), and N_s^{eq} is the equivalent input noise for the signal [15]. The measurement capability is given by

$$T_m = R_m^{\text{out}}/R_s^{\text{in}} = V_s^{\text{in}}/(V_s^{\text{in}} + N_m^{\text{eq}}), \quad (3)$$

where N_m^{eq} is the equivalent input noise for the meter channel. A device characterized by $N_s^{\text{eq}}N_m^{\text{eq}} < 1$, and thus leading to a value of $T_s + T_m > 1$ for a coherent input beam, improves the overall information transfer compared to any phase-insensitive device, and can therefore be said to operate in the quantum domain [16].

The third criterion is estimated by a conditional variance $W_{s|m}$ which gives the variance of the noise that can be obtained after correction of the signal output with the information taken out from the meter output. A value of $W_{s|m}$ smaller than 1 indicates nonclassical operation in the usual sense.

We note that the original definition of QND measurements [12] used conditions on the measurement interaction itself. On the other hand, these quantitative criteria define a ‘‘QND-like’’ coupling by its functionality, looking only at the input and output beams and considering the device itself as a ‘‘black box.’’ What matters here is that the processing of the quantum noise by the device is ‘‘nonclassical’’ in the usual sense, used, e.g., in squeezing experiments.

The experimental setup is schematically depicted in Fig. 1. The measurement apparatus itself consists in a

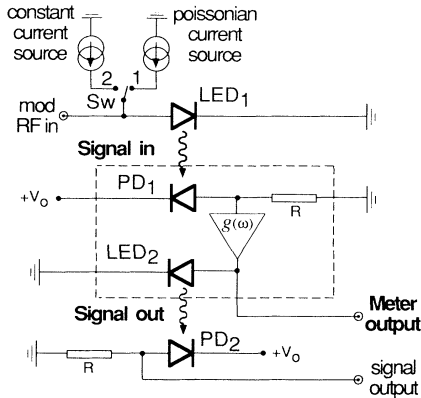

FIG. 1. Schematic experimental setup. The measurement device is enclosed in the dashed box. LED_{1,2} and PD_{1,2} are cooled at 100 K. The Poissonian current source consists of three parallel connected photodiodes, illuminated by white incandescent lamps. When switch Sw is in position 1, LED₁ is driven by a shot-noise-limited current; when in position 2, LED₁ is driven by a constant (filtered) current, and therefore shines squeezed light on PD₁. LED₂ can also be driven by the Poissonian current source, in order to get a shot-noise reference on PD₂. Note that, for clarity, all the electrical filtering is not represented in the figure.

large area *p-i-n* silicon photodiode PD₁ of quantum efficiency $\eta=0.90 \pm 0.05$ [21], followed by a low noise electronic amplifier, and a light emitting diode LED₂ [22]. The current to current conversion rate of the LED-PD system is $\epsilon=0.16$ at room temperature and $\epsilon=0.28$ at 100 K [23]. The detectors are placed as close as possible to the LED to maximize light collection and are introduced into a liquid nitrogen cryostat. The bandwidth of operation is from 150 to 350 kHz, the lower limit being due to electronic cutoff, and the upper one to the finite response time of the LED. From these numbers, it appears that if the LED is series connected with the photodiode, without any amplifier, the transfer coefficients for a shot-noise-limited input will be, respectively, $T_s = \eta\epsilon$ and $T_m = \eta$, leading to a rather small effect ($T_s + T_m = 1.15 \pm 0.06$ at 100 K), mainly due to the low conversion rate of the LED. In order to overcome this limitation, the current coming from the photodiode is amplified prior to being sent to the LED, which makes the conversion back to light less sensitive to vacuum fluctuations [24], and therefore greatly improves the nondegradation property of the system without changing the others. The equivalent input noise for the signal reads then

$$N_s^{\text{eq}} = \frac{1-\eta}{\eta} + \frac{1}{\eta} \beta_{\text{ampl}} + \frac{1}{\eta g_{\text{eff}}} \frac{1-\epsilon}{\epsilon}, \quad (4)$$

where β_{ampl} is the noise of the electronic amplifier relative to the shot-noise level, and $g_{\text{eff}} = g^2/G$ with g being the ac gain of the amplifier and G the dc gain. The distinction between ac and dc gain, allowed in our experimental setup, is an extra degree of freedom given by electronics compared to optics. Note that for practical purposes in information transmission, one has to choose $G = g$, which leads to $g_{\text{eff}} = g$. The structure of Eq. (4) illustrates a well-known feature in electronics, which is the fact that in a chain of amplifiers each element contributes to the total equivalent input noise by adding a term which is its own equivalent input noise divided by the gain of the chain up to itself. Thus the first term is due to the photodiode, and the second term is the contribution of the electronic amplifier divided by the gain η of the photodiode. In our experiment, this noise is 20 dB below the shot-noise level and can therefore be neglected. The last term is due to the LED, whose contribution can be made arbitrarily small by increasing the gain g_{eff} . On the other hand, the fidelity of the measurement channel is only restricted by the quantum efficiency of the photodiode PD₁, and one has

$$N_m^{\text{eq}} = (1-\eta)/\eta. \quad (5)$$

Finally, the conditional variance is limited by the conversion rate of LED₂ and is given by

$$W_{s|m} = 1 - \epsilon. \quad (6)$$

For a shot-noise-limited input, and assuming a negligible amplifier noise, the corresponding transfer coefficients read

$$T_m = \eta, \quad (7)$$

$$T_s = \eta \frac{1}{1 + (1/g_{\text{eff}})(1 - \epsilon)/\epsilon}. \quad (8)$$

In the high gain limit ($g_{\text{eff}} \rightarrow +\infty$), the sum of these two coefficients goes to $T_s + T_m = 2\eta$ and does not depend on LED₂'s conversion rate ϵ anymore.

In our experiment, the input light beam is the light coming from LED₁, and can therefore be either squeezed (switch Sw in position 2) or shot-noise limited (Sw in position 1) [25]. The evaluation of the transfer coefficient is performed by modulating the input signal light (at 250 kHz) by addition of a small RF modulation to LED₁ Poissonian driving current. The input signal-to-noise ratio R_s^{in} is deduced from the direct measurement of R_m^{out} on a spectrum analyzer, taking into account the quantum efficiency of PD₁ according to Eqs. (3) and (5). The SNR of the signal output R_s^{out} is visualized on the output of PD₂. For high gain ($g_{\text{eff}} = 100$), no distinction between R_m^{out} and R_s^{out} can be made within our experimental precision (about 3%), and therefore $T_s = T_m = \eta = 0.90 \pm 0.05$, i.e., $T_s + T_m = 1.8 \pm 0.1$. We show in Fig. 2 the experimental evolution of T_s/η with the gain g_{eff} , and compare it with the theoretical expression given by Eq. (8), demonstrating thereby a good theory-experiment agreement.

For the observation of the conditional variance, we have to correct the signal output by subtracting the meter output, using a 0° – 180° RF power combiner, in order to get the signal fluctuations down to below the shot noise. This requires a careful adjustment of the relative RF phase, since the fluctuations to be subtracted are both about 20 dB above the shot noise. The results are shown in Fig. 3, where the noise of the signal output is corrected down to 1.2 ± 0.1 dB below its shot noise. This yields $W_{s|m} = 0.76 \pm 0.02$, while the theoretical value, according to Eq. (6), is $W_{s|m} = 0.72$.

Owing to the possibility of having amplitude squeezed signal light at the input when LED₁ is driven by a constant current, we can also use this setup for both detect-

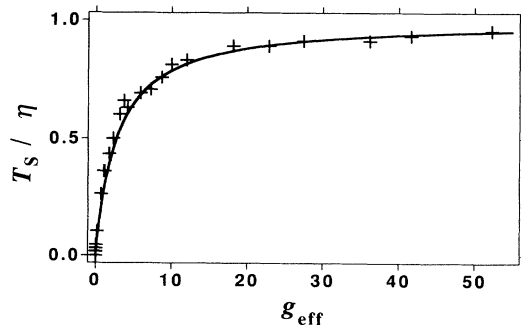

FIG. 2. Evolution of the signal transfer coefficient T_s versus the intermediate electronic amplifying gain g_{eff} . The experimental points are compared with the theoretical prediction [Eq. (8)]. The dc currents in the experiment are 25 mA for the LED and 7 mA for the PD.

ing and “recreating” an input squeezed state. In the high gain regime, the signal output beam is far above shot noise, but a squeezed output beam can be recovered by decreasing the gain g_{eff} to unity, where our system still operates in the quantum domain. For squeezed inputs, it is more convenient to use the equivalent input noises N_s^{eq} and N_m^{eq} , which are an input state independent characterization of the device, in contrast with T_s and T_m [see Eqs. (2) and (3)]. For $g_{\text{eff}} = 1$, Eqs. (4) and (5) give $N_s^{\text{eq}} = 3.0$ and $N_m^{\text{eq}} = 0.1$, so that $N_s^{\text{eq}} N_m^{\text{eq}} = 0.3$. If an input squeezed beam with variance V_s^{in} is shined on our experiment apparatus, the variances of the two output channels are given by

$$V_s^{\text{out}} = \eta \epsilon (V_s^{\text{in}} + N_s^{\text{eq}}), \quad (9)$$

$$V_m^{\text{out}} = \eta (V_s^{\text{in}} + N_m^{\text{eq}}). \quad (10)$$

The input variance V_s^{in} is inferred from the measured degree of squeezing on the meter channel ($V_m^{\text{out}} = 0.80$), as is usually done for a nonideal photodetector. The signal output squeezing given by Eq. (9) is then $V_s^{\text{out}} = 0.95$, which is consistent with the directly measured value $V_s^{\text{out}} = 0.93 \pm 0.03$. In that case, the experimental value of the conditional variance is $W_{s|m} = 0.79 \pm 0.02$ (-1.0 ± 0.1 dB). All these results clearly show that our scheme does operate in the QND regime, while having a squeezed signal beam, both at the input and the output.

In conclusion, we have demonstrated that a device using semiconductor light receivers and emitters meets all the criteria for QND measurements introduced in Refs. [14,15]. The experiment could actually be described as an initial destructive measurement, followed by the “recreation” of the measured light beam with the same clas-

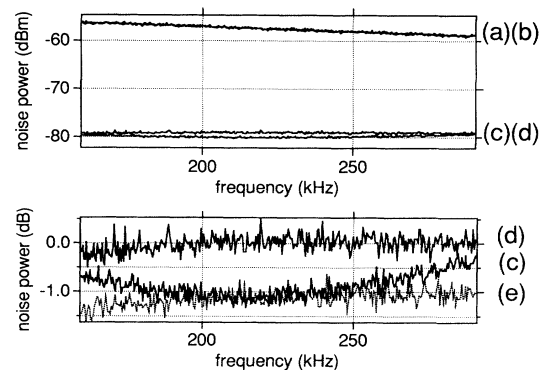

FIG. 3. The upper diagram shows the amplified signal output (trace *a*) and the meter output (trace *b*) for an effective gain $g_{\text{eff}} = 100$. The noise spectra are recorded with a resolution bandwidth of 10 kHz and a 25 Hz video filter. Trace *c* is the combined noise level, which goes 1.2 ± 0.1 dB below the shot-noise level on PD₂ (trace *d*). The lower diagram is a closeup, showing the noise power spectrum normalized to the shot noise. Trace *e* is the squeezing on PD₂ obtained by driving LED₂ with a constant current, which is also the best achievable noise reduction. The frequency dependence of trace *c* when compared to the other ones is due to electronic phase shifts.

sical and quantum intensity variations [26]. The lack of efficiency of the reemission stage can be compensated for by using intermediate electronic gain, which improves the quantum-noise-limited information transfer through the device but does not change the output quantum correlations [27]. The perspective of emergence of very high efficiency single-mode LED (see, for instance, Ref. [28]), or alternatively the technological realization of low threshold laser diodes, makes this type of system very promising for a realistic implementation in ultralow noise optical telecommunication networks.

We acknowledge the efficient technical assistance of G. Roger, F. Contet, J. C. Rodier, and A. Villing. We are also grateful to A. Brun for the loan of the cryostat. This work is supported by the EEC Contract ESPRIT III No. 6934. Institut d'Optique Théorique et Appliquée is URA 14 of the Centre National de la Recherche Scientifique.

Note added.— A preliminary account of this work was presented at the conference “Fundamentals of Quantum Optics III,” Kuhtai, Austria, March 1993, edited by F. Ehlotzky (Springer-Verlag, Berlin, to be published). See also a related work independently done by A. Karlsson, E. Goobar, G. Bjork, and J. P. Rigole, 93 CLEO conference, paper No. QThF5, May 1993 (unpublished).

- [1] R. J. Glauber, in *Proceedings of Ecole d'Eté des Houches 1964*, edited by C. De Witt, A. Blandin, and C. Cohen-Tannoudji (Gordon and Breach, New York, 1965).
- [2] Special issues on squeezed light: *J. Opt. Soc. Am. B* **4**, 1450 (1987); *J. Mod. Opt.* **34**, 709 (1987).
- [3] S. Machida and Y. Yamamoto, *Opt. Commun.* **57**, 290 (1986); S. Machida, Y. Yamamoto, and Y. Itaya, *Phys. Rev. Lett.* **58**, 1000 (1987).
- [4] M. C. Teich and B. E. A. Saleh, *J. Opt. Soc. Am. B* **2**, 275 (1985).
- [5] P. R. Tapster, J. G. Rarity, and J. S. Satchell, *Europhys. Lett.* **4**, 293 (1987).
- [6] P. J. Edwards, *Int. J. Optoelectron.* **6**, 23 (1991); P. J. Edwards and G. H. Pollard, *Phys. Rev. Lett.* **69**, 1757 (1992).
- [7] H.-A. Bachor, P. Rottengatter, and C. M. Savage, *Appl. Phys. B* **55**, 258 (1992).
- [8] E. Goobar, A. Karlsson, G. Björk, and P.-J. Rigole, *Phys. Rev. Lett.* **70**, 437 (1993).
- [9] J. B. Johnson, *Phys. Rev.* **32**, 97 (1928); H. Nyquist, *Phys. Rev.* **32**, 110 (1928).
- [10] R. H. Koch, D. J. Van Harlingen, and J. Clarke, *Phys. Rev. B* **26**, 74 (1982).
- [11] F. Capasso and M. C. Teich, *Phys. Rev. Lett.* **57**, 1417 (1986).
- [12] V. B. Braginsky, Y. L. Vorontsov, and K. S. Thorne, *Science* **209**, 547 (1980).
- [13] J. H. Shapiro, *Opt. Lett.* **5**, 351 (1980).
- [14] M. J. Holland, M. J. Collett, D. F. Walls, and M. D. Levenson, *Phys. Rev. A* **42**, 2995 (1990).
- [15] P. Grangier, J. M. Courty, and S. Reynaud, *Opt. Commun.* **89**, 99 (1992).
- [16] J. F. Roch, G. Roger, P. Grangier, J. M. Courty, and S. Reynaud, *Appl. Phys. B* **55**, 291 (1992).
- [17] J.-Ph. Poizat and P. Grangier, *Phys. Rev. Lett.* **70**, 271 (1993).
- [18] W. H. Richardson, S. Machida, and Y. Yamamoto, *Phys. Rev. Lett.* **66**, 2867 (1991).
- [19] J. A. Levenson, I. Abram, T. Rivera, P. Fayolle, J. C. Garreau, and P. Grangier, *Phys. Rev. Lett.* **70**, 267 (1993).
- [20] Y. Yamamoto, *Trans. Inst. Electron. Inf. Commun. Eng., Sect. E* **73**, 1598 (1990).
- [21] The conservative error bar is due to the large spectral width and solid angle of the incoming light emitted by LED₁, which make an accurate measurement of the photodiode quantum efficiency difficult.
- [22] The photodiodes are EGG model C30809E, with a 50 mm² sensitive area. The LED are Hamamatsu model L2656, which, for a driving current of 20 mA, give at 300 K a total output power of 6 mW, centered around 890 nm. The electronic amplifiers, including the intermediate ac gain between PD₁ and LED₂, are realized with linear low-noise FET input preamplifiers OEI AH0013.
- [23] The conversion rate ϵ includes therefore the quantum efficiency η of the photodiode PD₂.
- [24] H. P. Yuen, *Phys. Rev. Lett.* **56**, 2176 (1986).
- [25] The shot-noise level is obtained by driving LED₁ with a Poissonian current, generated with photodiodes illuminated by white incandescent lamps (see Ref. [7]). Three parallel connected photodiodes were required in order to get high enough photocurrent without saturating each photodiode. We have checked that, in this case, the light shining on PD₁ has the same noise power as the one obtained by a direct illumination on this photodiode using a white incandescent lamp.
- [26] In this device, the quantum statistics for the intensity is preserved, but all informations relative to the phase (and also to the other variables of the input beam) are lost in the initial detection process. On the other hand, in the original QND concept, the perturbation of the system was implicitly supposed to be kept to the minimum allowed by the Heisenberg uncertainty principle. Therefore, our set-up may appear as a strongly “nonminimum” QND device, in the same sense as one may speak about nonminimum squeezed states (i.e., with sub-shot-noise for one quadrature, but large excess noise for the product of both quadratures).
- [27] It is worth pointing out that having a signal gain close to 1 is an extra requirement with respect to the three QND criteria, which appears when one is concerned by preserving not only the SNR but also the degree of squeezing of the input signal. On the other hand, the three QND criteria can be fulfilled with arbitrary large gain (see, e.g., Ref. [19]).
- [28] E. Yablonovitch *et al.*, *Phys. Rev. Lett.* **67**, 3380 (1991), and references therein.