

Megawatt peak power, 1 kHz, 266 nm sub nanosecond laser source based on single-crystal fiber amplifier (orale)

Loïc Deyra, Igor Martial, François Balembois, Julien Didierjean, Patrick Georges

► To cite this version:

Loïc Deyra, Igor Martial, François Balembois, Julien Didierjean, Patrick Georges. Megawatt peak power, 1 kHz, 266 nm sub nanosecond laser source based on single-crystal fiber amplifier (orale). Conference on Lasers and Electro-Optics Europe & International Quantum Electronics Conference (CLEO/Europe-IQEC), May 2013, Munich, Germany. hal-00818721

HAL Id: hal-00818721

<https://hal-iogs.archives-ouvertes.fr/hal-00818721>

Submitted on 30 Apr 2013

HAL is a multi-disciplinary open access archive for the deposit and dissemination of scientific research documents, whether they are published or not. The documents may come from teaching and research institutions in France or abroad, or from public or private research centers.

L'archive ouverte pluridisciplinaire **HAL**, est destinée au dépôt et à la diffusion de documents scientifiques de niveau recherche, publiés ou non, émanant des établissements d'enseignement et de recherche français ou étrangers, des laboratoires publics ou privés.

Megawatt peak power, 1 kHz, 266 nm sub nanosecond laser source based on single-crystal fiber amplifier

Loïc Deyra¹, Igor Martial², François Balembois¹, Julien Diderjean², Patrick Georges¹

1. Laboratoire Charles Fabry, Institut d'Optique, CNRS, Univ Paris-Sud, 91127 Palaiseau, France

2. Fibercryst SAS, La Doua Bâtiment l'Atrium, Boulevard Latarjet, F 69616 Villeurbanne Cedex, France

The development of solid state UV lasers is major industrial challenge for various applications, among them spectroscopy, lithography, material processing, or ophthalmology.

Various optical designs have been used to obtain high conversion efficiencies, the two most efficient being cavity enhanced setups for CW fourth harmonic generation [1] or high peak power external frequency conversion schemes. Among the latest, record efficiencies have been obtained by microchip lasers [2], but the average power and beam quality were limited. In most of those systems, a master oscillator power amplifier (MOPA) is used to increase the fundamental beam energy [3-4]

In the past few years, single-crystal fiber (SCF) technology has proved to be an interesting solution to boost the performance of passively Q-switched microchip lasers [5]: it provides unique combination of high gain, high peak power and significant average power, with the most simple amplification scheme possible (one or two passes).

In this paper, we present a 266 nm UV source based on the fourth harmonic generation of a Nd:YAG single-crystal fiber MOPA previously developed [4].

The 1064 nm amplified laser system is described in detail in [5]. A Q-switched microchip laser is amplified with a Nd:YAG single-crystal fiber in double pass configuration. It delivers a maximum of 2.3 W at 1 kHz with pulses of 550 ps (2.3 mJ pulses) and an excellent beam quality ($M^2=1.06$), reaching a peak power of more than 4 MW.

The frequency conversion scheme (Fig.1) is based on harmonic generation LBO/BBO crystals. We reached 22.7% of total conversion efficiency from infrared to UV. We obtained a 266 nm output of 530 mW (Fig.2), at 1 kHz with pulses width of 540 ps. This represents a peak power of 980 kW. We measured the UV beam profile and determine its M^2 to be <2 . To the best of our knowledge, this is the first realization of a 266 nm sub nanosecond source based on passively Q-switched oscillator with MW peak power combined with half-watt average power. This work demonstrates the potential of single-crystal fiber amplifiers for high performance UV MOPA systems

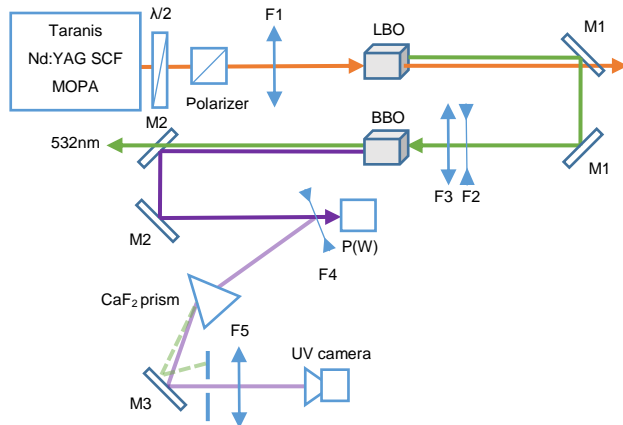

Figure 2: Experimental setup (SCF: single crystal fiber)

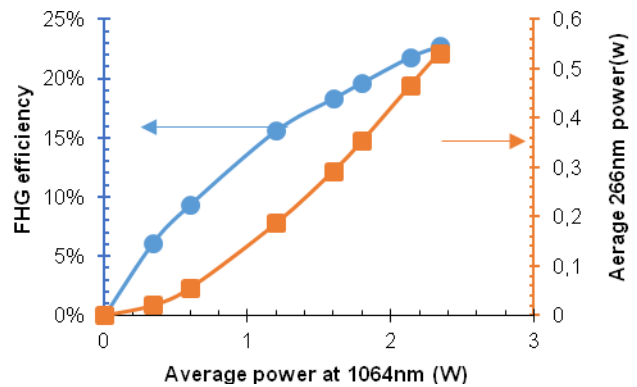

Figure 1 : Average power at 266 nm obtained (right axis) and IR to UV conversion efficiency (left)

References

1. T. Südmeyer, Y. Imai, H. Masuda, N. Eguchi, M. Saito, and S. Kubota, *Optic Express*, vol. 16, no. 3, pp. 1546–1551 (2008)
2. R. Bhandari, T. Taira, A. Miyamoto, Y. Furukawa, and T. Tago, *Optical Materials express*, vol. 2, no. 7, pp. 907–913 (2012)
3. Y. Zaouter, M. Hanna, F. Morin, M. Tonin, R. Maleck, C. Hoenninger, E. Mottay, and P. Georges, *Lasers, Sources, and Related Photonic Devices*, OSA Technical Digest (CD) (Optical Society of America, 2012), paper FTh5A.2.
4. S. Pierrot, F. Liegeois, J. Saby, B. Cocquelin, Y. Hernandez, F. Salin, and D. Giannone, *Fiber Laser Applications*, OSA Technical Digest (CD) (Optical Society of America, 2011), paper JWA5.
5. Rakesh Bhandari and Takunori Taira, *Optic Express*, vol. 19, pp. 19135-19141 (2011)