



HAL
open science

Polarization independent phase demodulation using photorefractive two-wave mixing

Philippe Delaye, Alain Blouin, Denis Drolet, Jean-Pierre Monchalin,
Louis-Anne de Montmorillon, Gérald Roosen

► **To cite this version:**

Philippe Delaye, Alain Blouin, Denis Drolet, Jean-Pierre Monchalin, Louis-Anne de Montmorillon, et al.. Polarization independent phase demodulation using photorefractive two-wave mixing. Applied Physics Letters, 1999, 74 (21), pp.3087-3089. 10.1063/1.124070 . hal-00673451

HAL Id: hal-00673451

<https://hal-iogs.archives-ouvertes.fr/hal-00673451>

Submitted on 23 Feb 2012

HAL is a multi-disciplinary open access archive for the deposit and dissemination of scientific research documents, whether they are published or not. The documents may come from teaching and research institutions in France or abroad, or from public or private research centers.

L'archive ouverte pluridisciplinaire **HAL**, est destinée au dépôt et à la diffusion de documents scientifiques de niveau recherche, publiés ou non, émanant des établissements d'enseignement et de recherche français ou étrangers, des laboratoires publics ou privés.

Polarization independent phase demodulation using photorefractive two-wave mixing

Philippe Delaye^{a)}

Laboratoire Charles Fabry de l'Institut d'Optique, Unité Mixte de Recherche 8501 du Centre National de la Recherche Scientifique, Bat. 503, Centre Scientifique d'Orsay, B. P. 147, 91403, Orsay Cedex, France

Alain Blouin, Denis Drolet, and Jean-Pierre Monchalin

Industrial Materials Institute, National Research Council of Canada, 75 de Mortagne, Boucherville, Quebec, J4B 6Y4, Canada

Louis-Anne de Montmorillon and Gérald Roosen

Laboratoire Charles Fabry de l'Institut d'Optique, Unité Mixte de Recherche 8501 du Centre National de la Recherche Scientifique, Bat. 503, Centre Scientifique d'Orsay, B. P. 147, 91403, Orsay Cedex, France

(Received 19 November 1998; accepted for publication 23 March 1999)

We describe both theoretically and experimentally a polarization independent interferometric adaptive photodetector based on photorefractive two-wave mixing. The configuration is based on the simultaneous recording of two independent gratings in a single photorefractive crystal. Applied to the detection of ultrasonic signals, this interferometric photodetector operates with depolarized beams issued from multimode fibers and gives a detection limit close to the ultimate. © 1999 American Institute of Physics. [S0003-6951(99)01021-9]

Adaptive interferometric photodetectors have been studied for almost ten years¹ and applied to the detection of phase modulated beams in fields as different as free space communications² and detection of ultrasonic vibrations.³⁻⁵ For these applications the main advantage of adaptive interferometric photodetectors is that the constraints on wave front structure and alignment of the signal beam that carries the phase modulation information are considerably relaxed compared to a classical homodyne detection scheme. Such an adaptive interferometric photodetector can be based on two-beam coupling in a photorefractive crystal.¹⁻⁵ Several configurations of this adaptive photodetector have been studied to perform efficient linear detection of the phase modulation imprinted on a signal beam⁵ (isotropic or anisotropic diffraction with or without electric field applied to the crystal). For all these configurations, the best sensitivity is obtained for signal and pump beams having linear and parallel polarization. When the signal beam is transmitted by a multimode fiber, it is completely depolarized. Hence, half of the incident energy is lost by polarizing the signal beam and the detection limit is degraded by a factor of $\sqrt{2}$. To operate with the whole signal beam intensity, independently of its polarization state, a setup with two crystals, one for each perpendicular polarization component, can be used.^{6,7} This setup is rather cumbersome, since it requires in particular the use of two pump beams. In this letter, we propose a configuration based on a single crystal that allows a direct measurement of the phase modulation imprinted on a depolarized beam and uses the whole power of the signal beam.

We consider the two-wave mixing ultrasound detection setup we have developed⁵ and in which the signal beam is carried from the tested sample to the photorefractive crystal by a multimode fiber. The beam issued from the multimode

fiber is depolarized, which means that each individual grain of the output speckled structure has a definite polarization state that is completely random compared to the polarization of its neighbors. When the output of such a multimode fiber is sent onto a polarizing beamsplitter, the power is equally split (we suppose that the fiber length is sufficient to assure a complete depolarization of the beam) over each port of the beamsplitter (whatever its orientation), in two uncorrelated speckled structures. The beam issued from the fiber can thus be considered as the spatially incoherent superposition of two speckled structures with orthogonal polarizations, which are mixed in the photorefractive crystal with a temporally coherent pump beam.

If the pump beam is linearly polarized, only the component of the signal beam with the same polarization state contributes to the formation of the interference illumination pattern and gives rise to the photorefractive grating. To use all the power of the signal beam, both polarization components have to interfere with the pump beam. Thus we need a pump beam that contains both polarization components and that is able to write in the photorefractive crystal two independent holograms, each one associated to each polarization component. The two polarization components have to be spatially incoherent, while being both temporally coherent with the signal beam. The simplest way to fulfill this condition is to have a speckled depolarized pump beam, i.e., a pump beam issued from a multimode fiber as for the signal beam.

So the system we designed is based on two depolarized signal and pump beams, which are issued from multimode fibers (Fig. 1). The configuration used is identical to the one which makes use of anisotropic diffraction and was previously described.^{8,5} In the case of a 43 m crystal, such as CdTe, the two beams propagate along the (110) direction, writing a grating vector along (110). The crystal is followed by a 45° polarizing beamsplitter of axes along the directions a and b. The eigenaxes of the photorefractive crystal are also

^{a)}Electronic mail: philippe.delaye@iota.u-psud.fr

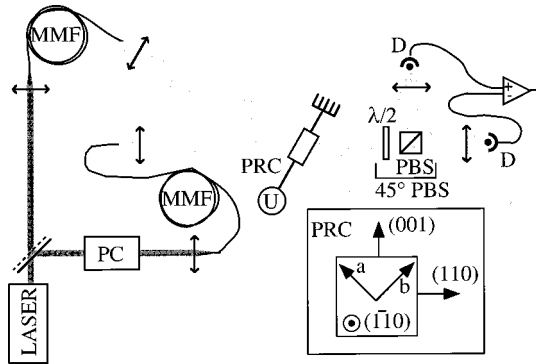

FIG. 1. Setup for the implementation of the polarization independent configuration. The setup uses a Nd:YAG laser ($\lambda=1.06 \mu\text{m}$), a Pockels cell (PC) as a phase modulator, and multimode fibers (MMF) to depolarize the beams. A half wave plate ($\lambda/2$) and a polarizing beamsplitter (PBS) simulate the 45° PBS. A voltage U is applied to the photorefractive crystal (PRC). The signal is received by two identical detectors (D). The orientations of the PBS and of the PRC are shown in the inset.

along a and b , so we make all the calculations in the (a,b) axes system (Fig. 1). Signal and pump beams polarized along the a axis write a grating characterized by a given photorefractive gain, whereas the polarization components along the b axis see a gain of the same amplitude but with opposite sign. If we now consider the two depolarized pump $E_p(x,t)$ and signal $E_s(x,t)$ beams (having intensities $I_p(x,t)$ and $I_s(x,t)$, respectively), they can both be considered as the incoherent sum of two uncorrelated beams crossed polarized along directions a and b , $E_{p(s)a}(x,t)$ and $E_{p(s)b}(x,t)$, respectively. Each polarized component of the signal beam interferes with the corresponding component of the pump beam and thus two holograms are written in the photorefractive crystal. Each pump beam component (a) or (b) can only read the hologram it wrote and not the other one, as in the case of a phase encoded holographic memory system.⁹

We now consider the two-beam coupling setup in the normal regime of operation of the ultrasonic sensor,⁵ which means a signal beam phase modulated with an amplitude much smaller than π and at a frequency much greater than the inverse of the response time of the photorefractive effect. We assume that the angular spread of the speckle beam is sufficiently small, so that the photorefractive gain does not vary significantly with the incident direction, which means that the étendue or throughput¹⁰ of the whole system is limited by the étendue of the multimode fiber. In these conditions, the diffraction equations of both components of the signal beam are written as follows:

$$\frac{\partial E_{sa}}{\partial x} = + \frac{2\gamma}{E_{sc}} E_{1a}(x) E_{pa} + \left(i\beta_E - \frac{\alpha}{2} \right) E_{sa}, \quad (1)$$

$$\frac{\partial E_{sb}}{\partial x} = - \frac{2\gamma}{E_{sc}} E_{1b}(x) E_{pb} - \frac{\alpha}{2} E_{sb}, \quad (2)$$

where E_{sc} is the strength of the space charge field, α is the absorption of the crystal, and β_E is a Pockels phase shift between the eigenpolarization components that may eventually exist when an electric field is applied, γ is the photorefractive gain in amplitude which would exist if only one grating was present. The diffraction terms (first term on the right-hand side) contain only the phase matched part $E_{1a(b)}$

of the steady-state space charge field grating E_1 , (instead of the same term ($E_{1a} + E_{1b}$) for both components in the anisotropic diffraction configuration). In the undepleted pump approximation, $I_s \ll I_p$, we have

$$E_{1a(b)}(x) = \frac{E_{sc}}{2} \frac{E_{pa(b)}^*(x,0) E_{sa(b)}(x,0)}{I_p(x,0)}. \quad (3)$$

Although independent, both space charge field gratings are affected by the orthogonal component of the pump beam which is seen as a uniform illumination of the crystal. This is illustrated in expression (3) by the presence of the total pump beam illumination $I_p(x,0)$ in the denominator. If each component was present alone, the denominator would be replaced by $I_{pa}(x,0) = I_{pb}(x,0) = I_p(x,0)/2$. Hence, the available gain of each hologram is reduced by a factor of 2 when compared to a single polarization setup.

This setup is equivalent to two independent two-wave mixing experiments, perfectly uncorrelated, for each polarization component, and with a photorefractive gain γ that is equally shared between the two components. After the crystal, both components are sent onto a polarizing beamsplitter oriented along a and b axes that directs them onto two detectors, which measure

$$I_{sa(b)} = e^{-\alpha x} I_{sa(b)}(0,0) \left[e^{\pm \gamma' x} - 2e^{\pm \gamma' x/2} \sin\left(\pm \frac{\gamma'' x}{2}\right) \varphi(t) \right], \quad (4)$$

where $\varphi(t)$ is the phase modulation [$= 4\pi\delta(t)/\lambda$, if induced, as in the case of ultrasound detection, by a surface displacement $\delta(t)$] and $\gamma = \gamma' + i\gamma''$, the \pm sign depending on the axis a or b .

If we make the difference of signals given by the two detectors we obtain [as $I_{sa}(0,0) = I_{sb}(0,0) = I_s/2$]

$$S(x,t) = e^{-\alpha x} I_s \left[\text{sh } \gamma' x - 2 \text{ch} \left(\frac{\gamma' x}{2} \right) \sin \left(\frac{\gamma'' x}{2} \right) \varphi(t) \right]. \quad (5)$$

The modulated part of the signal S [Eq. (5)] and the constant part of I_{sa} and I_{sb} [Eq. (4)] allow to calculate the signal-to-noise ratio (SNR),⁵ from which we deduce the normalized limit of detection δ_1 (which is the smallest displacement amplitude giving a SNR of 1 with an electronic measurement bandwidth of 1 Hz and an incident power of 1 W) and the relative detection limit δ_{rel} (relative to the ultimate limit of interferometric detection)

$$\delta_1 = \frac{\lambda}{4\pi} \sqrt{\frac{h\nu}{2\eta}} e^{\alpha x/2} \frac{\sqrt{1 + \text{th}^2 \gamma' x/2}}{\sin \gamma' x/2} = \frac{\lambda}{4\pi} \sqrt{\frac{h\nu}{2\eta}} \delta_{rel}, \quad (6)$$

λ being the wavelength of the photons, $h\nu$ their energy, and η the quantum efficiency of the detectors. Even if we obtain here the same kind of expression as Eq. (8) in Ref. 5, there is, however, a difference. In Ref. 5 we considered polarized beams, whereas here we consider depolarized beams. Configurations described in Ref. 5 used with depolarized beams rather than with polarized ones would yield to a SNR reduced by a factor of $\sqrt{2}$ resulting from the energy loss from the polarizer. Such a reduction is not present in the new configuration. On the other hand, the photorefractive gain is less efficiently used, but a value of δ_{rel} close to one can, nevertheless, be obtained, by increasing γ'' using a higher applied electric field, for example.

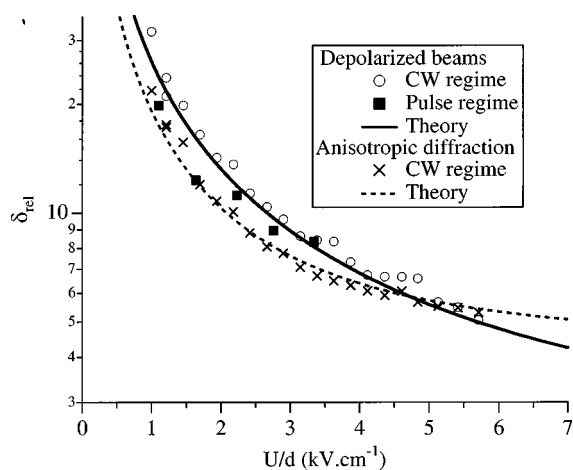

FIG. 2. Comparison of experimental and theoretical values of δ_{rel} as a function of U/d , for depolarized beams and anisotropic diffraction. Due to the absorption of the crystal,¹¹ the minimum relative detection limit is 3.

We now present the experimental demonstration of the polarization independent detection. We use a typical two-beam coupling setup, with large core multimode fibers of 30 m length to couple the signal and the pump beams onto a CdTe:V crystal (Fig. 1).

In a first set of experiments using a low power continuous wave (CW) laser, two measurements were performed, a first one with depolarized beams and a second one with vertically polarized beams. In both cases, we measure the average signal \bar{I}_s on the detector and its modulated part ΔI_s . We deduced from this data the relative detection limit assuming that the dominating noise is the photon noise (which was, in fact, not the case due to the large laser intensity noise in the frequency region of our measurement, only partially eliminated by our differential setup). The results were normalized to the power of the signal beam at the output of the fiber. Corrections for the reflection losses at the faces of the crystal were made. The experimental results for both configurations are compared in Fig. 2, as a function of the applied electric field U/d .

Another set of experiments was performed in a slightly different way with a setup and a procedure previously described and discussed in detail in Ref. 5. We use a high power pulsed laser, and make a true SNR measurement (i.e., we measure the rms value of the signal and the rms value of the noise that was mostly photon noise, see Ref. 5 for details of the measurement), with the same photorefractive crystal and depolarized beams. High power pulsed lasers are required when working with strongly scattering surfaces with low reflecting properties or when short photorefractive response time is required to compensate for ambient vibrations or movements of the inspected parts. The experimental points (black squares) are shown in Fig. 2. It is noted that the experimental results obtained in both experiments are similar despite the very different experimental conditions.

In order to compare the experimental results with the theoretical predictions, we used the experimental values of

the gain (γ' and γ'') obtained with the same crystal (noted B.V-4T3.9)¹¹ in expression (6) for the depolarized beam configuration and into the corresponding expression of $\delta_{rel} = \sqrt{2} e^{\alpha x/2} \sqrt{1 + |\gamma|^2 x^2} / \gamma'' |x$ that can be calculated for an anisotropic diffraction configuration.⁵ There is a good agreement between experimental results and theoretical curves. To obtain this agreement we had to introduce a supplementary 0.67 screening factor to the previously obtained results.¹¹ This effect is not explained at this time but is probably linked to the electrical breakdown problems previously encountered with this crystal. These electrical problems also prevented us from using electric fields higher than 6 kV cm^{-1} .

The theory predicts that at the optimum of each configuration, the polarization independent configuration should be $\sqrt{2}$ better than other configurations (used on depolarized beams). This is shown in the theoretical curves (Fig. 2, $U/d > 5 \text{ kV cm}^{-1}$) but not clearly observed experimentally, due to the electrical problems seen in our crystal.

We have theoretically and experimentally demonstrated a configuration of the photorefractive two-beam coupling ultrasound detector that allows measurements with both signal and pump beams coupled with large core optical fibers. In this configuration both beams are depolarized. This configuration uses only one photorefractive crystal and is very easy to implement. It is based on the creation of independent gratings inside the crystal. The performance of this polarization independent configuration is at least as good as the conventional setup using one polarization component of the beams. It could reach a detection limit close to the ultimate detection limit (reached with zero absorption). Furthermore, this setup is not limited to a two-beam coupling arrangement. It can also be used with a photoemf sensor,^{1,7} by measuring the transient current circulating in a photorefractive crystal illuminated by two depolarized beams issued from multimode fibers.

This polarization independent configuration is important for the development of the ultrasound detection system as it allows to carry the beams with multimode fibers and thus gives the possibility to implement a system with a deported measurement head.

The authors want to acknowledge J. C. Launay (Action Aquitaine de Recherche en Apesanteur, Bordeaux France) for growing the CdTe sample used in the experiments.

¹M. P. Petrov, S. I. Stepanov, and A. V. Khomenko, *Photorefractive Crystals in Coherent Optical Systems* (Springer, Berlin, 1991).

²F. M. Davidson and C. T. Field, *J. Lightwave Technol.* **12**, 1207 (1994).

³R. K. Ing and J. P. Monchalain, *Appl. Phys. Lett.* **59**, 3233 (1991).

⁴A. Blouin and J. P. Monchalain, *Appl. Phys. Lett.* **65**, 932 (1994).

⁵Ph. Delaye, A. Blouin, D. Drolet, L.-A. de Montmorillon, G. Roosen, and J. P. Monchalain, *J. Opt. Soc. Am. B* **14**, 1723 (1997).

⁶R. T. B. James and K. Iizuka, *J. Lightwave Technol.* **11**, 633 (1993).

⁷M. A. Celis Flores, P. Rodriguez Montero, and S. Stepanov, *Electron. Lett.* **34**, 797 (1998).

⁸I. Rossomakhin and S. Stepanov, *Opt. Commun.* **86**, 199 (1991).

⁹C. Alvés, G. Pauliat, and G. Roosen, *Opt. Commun.* **19**, 1894 (1994).

¹⁰W. H. Steel, *Appl. Opt.* **13**, 704 (1974).

¹¹L. A. de Montmorillon, Ph. Delaye, J. C. Launay, and G. Roosen, *J. Appl. Phys.* **82**, 5913 (1997).